

**ADCOM**<sup>®</sup>  
*details you can hear*

**GCA-510**

Control Amplifier

**OWNER'S MANUAL**

# THE FOLLOWING PRECAUTIONS AND SAFETY INSTRUCTIONS ARE REQUIREMENTS OF UL AND CSA SAFETY REGULATIONS

**Warning: To reduce the risk of fire or electric shock, do not expose this unit to rain or moisture.**

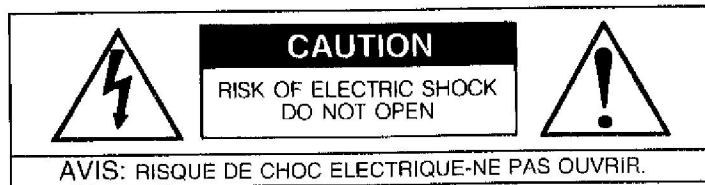

The graphic symbol of a lightning flash with an arrow point within a triangle signifies that there is dangerous voltage within the unit and it poses a hazard to anyone removing the cover to gain access to the interior of the unit. **Only qualified service personnel should make any such attempt.**



The graphic symbol of an exclamation point within an equilateral triangle warns a user of the device that it is necessary to refer to the instruction manual and its warnings for proper operation of the unit.



Do not place this unit on an unstable cart, stand, tripod, bracket, or table. The unit may fall, causing serious injury to a child or adult, and serious damage to the unit. Use only with a cart, stand, tripod, bracket, or table recommended by the manufacturer, or sold with the unit. Any mounting of the device should follow the manufacturer's instructions, and should use a mounting accessory recommended by the manufacturer.

Read all the safety and operating instructions before connecting or using this unit.

Retain this notice and the owner's manual for future reference.

All warnings on the unit and in its operating instructions should be adhered to.

All operating and use instructions should be followed.

Do not use this unit near water; for example, near a bathtub, washbowl, kitchen sink, laundry tub, in a wet basement, or near a swimming pool.

The unit should be installed so that its location or position does not interfere with its proper ventilation. For example, it should not be situated on a bed, sofa, rug, or similar surface that may block the ventilation openings; or placed in a built-in installation, such as bookcase or cabinet, that may impede the flow of air through its ventilation openings.

The unit should be situated away from heat sources such as radiators, heat registers, stoves, or other devices (including amplifiers) that produce heat.

The unit should be connected to a power-supply outlet only of the voltage and frequency marked on its rear panel.

The power-supply cord should be routed so that it is not likely to be walked on or pinched, especially near the plug, convenience receptacles, or where the cord exits from the unit.

Clean unit only as recommended in its instruction manual.

The power-supply cord of the unit should be unplugged from the wall outlet when it is to be unused for a long period of time.

Care should be taken so that objects do not fall, and liquids are not spilled, into the enclosure through any openings.

This unit should be serviced by qualified service personnel when:

- The power cord or the plug has been damaged; or
- Objects have fallen, or liquid has been spilled, into the unit; or
- The unit has been exposed to rain, or liquids of any kind; or
- The unit does not appear to operate normally, or exhibits a marked change in performance; or
- The device has been dropped, or the enclosure damaged.

**DO NOT ATTEMPT SERVICING OF THIS UNIT YOURSELF. REFER SERVICING TO QUALIFIED SERVICE PERSONNEL.**

## ATTENTION

POUR PRÉVENIR LES CHOCS ÉLECTRIQUES NE PAS UTILISER CETTE FICHE POLARISÉE AVEC UN PROLONGATEUR, UNE PRISE DE COURANT OU UNE AUTRE SORTIE DE COURANT, SAUF SI LES LAMES PEUVENT ÊTRE INSÉRÉES À FOND SANS EN LAISSER AUCUNE PARTIE À DÉCOUVERT.

## CAUTION

TO PREVENT ELECTRIC SHOCK DO NOT USE THIS POLARIZED PLUG WITH AN EXTENSION CORD, RECEPTACLE OR OTHER OUTLET UNLESS THE BLADES CAN BE FULLY INSERTED TO PREVENT BLADE EXPOSURE.

## CAUTION POWER LINES

Any outdoor antenna must be located away from all power lines.

### OUTDOOR ANTENNA GROUNDING

If an outside antenna is connected to your tuner or tuner-preamplifier, be sure the antenna system is grounded so as to provide some protection against voltage surges and built-up static charges. Section 810 of the National Electrical Code, ANSI/NFPA No. 70-1984, provides information with respect to proper grounding of the mast and supporting structure, grounding of the lead-in wire to an antenna discharge unit, size of grounding conductors, location of antenna discharge unit, connection to grounding electrodes, and requirements for the grounding electrode.

- Use No.10 AWG (5.3 mm<sup>2</sup>) copper, No.8 AWG (8.4 mm<sup>2</sup>) aluminum, No.17 AWG (1.0 mm<sup>2</sup>) copper-clad steel or bronze wire, or larger, as a ground wire.
- Secure antenna lead-in and ground wires to house with stand-off insulators spaced from 4-6 feet (1.22-1.83 m) apart.
- Mount antenna discharge unit as close as possible to where lead-in enters house.
- Use jumper wire not smaller than No.6 AWG (13.3 mm<sup>2</sup>) copper, or the equivalent, when a separate antenna-grounding electrode is used. See NEC Section 810-21 (j).

EXAMPLE OF ANTENNA GROUNDING AS PER NATIONAL ELECTRICAL CODE INSTRUCTIONS CONTAINED IN ARTICLE 810 - RADIO AND TELEVISION EQUIPMENT.

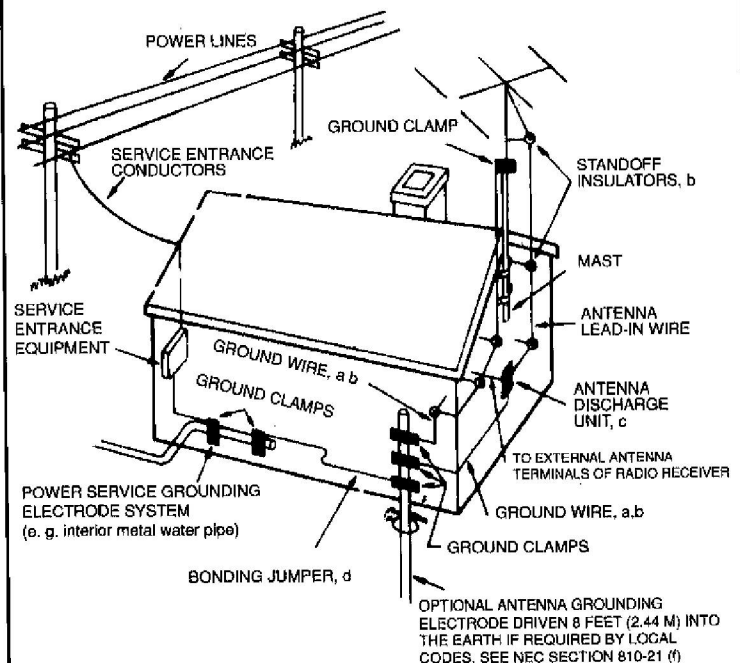

### NOTE TO CATV SYSTEM INSTALLER

This reminder is provided to call the CATV system installer's attention to Article 820-22 of the National Electrical Code that provides guidelines for proper grounding and, in particular, specifies that the cable ground shall be connected to the grounding system of the building, as close to the point of cable entry as practical.

## **INTRODUCTION**

Congratulations on purchasing ADCOM's GCA-510 Control Amplifier. We designed this unique product for both simple operation and exceptional sound quality. We don't anticipate any difficulty in setting up the GCA-510, but ask that you do read the following instructions carefully before you begin hooking up your new component.

## **CIRCUIT DESIGN CONSIDERATIONS**

The GCA-510 is an innovative example of the minimalist school of circuit design. Although it offers the convenience of an "integrated amplifier," it is actually a very high gain power amplifier preceded by a passive level controller. There is no separate preamplifier stage in the GCA-510 at all.

The circuit topology includes a two stage discrete front end with doubly regulated and temperature compensated active constant current bias sources. This gives exceptionally stable performance characteristics from DC to ultrasonic frequencies.

The output stage utilizes a unique Bias-Emitter Multiplier to amplify a transistor's inherent silicon junction voltage to create a temperature compensated constant voltage source. The complementary output stage features discrete high power devices operated in a high-bias Class AB Common Collector mode. This design employs no current limiting. Consequently, the amplifier is completely capable of driving low impedance loads without excessive distortion. The amplifier is also virtually impervious to speaker/cable reactance and will drive a fully phase shifted load with the same distortion performance exhibited with a purely resistive load. Precise loudspeaker control is further assured by the intentional elimination of output coils to provide a constant high damping factor over the entire audio range.

# FRONT and REAR PANELS

We carefully designed the GCA-510 with your enjoyment in mind. Controls are at a minimum and we've arranged them so that their use is truly intuitive. The rear panel benefits from the same design goals. Take a moment to familiarize yourself with the following drawings. You'll find references to the circled numbers throughout the rest of this manual.

## GCA 510 - FRONT PANEL DIAGRAM

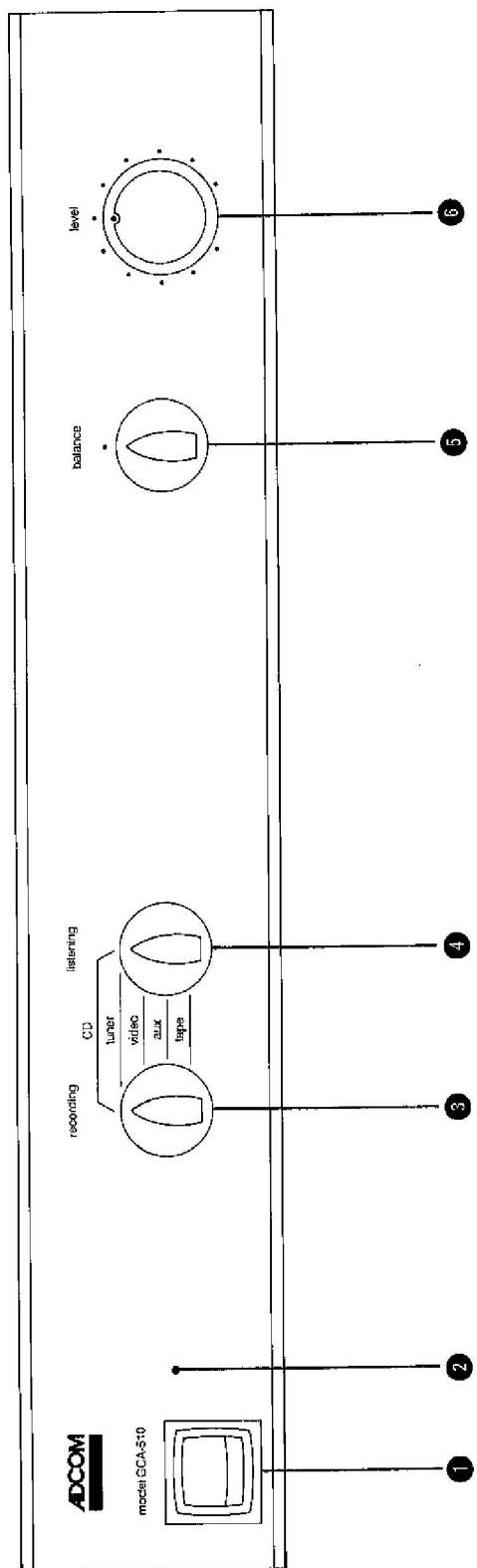

- 1 Power switch
- 2 Power indicator LED
- 3 Recording selector
- 4 Listening selector
- 5 Balance control
- 6 Level (Volume) control

# GCA - 510 REAR PANEL DIAGRAM

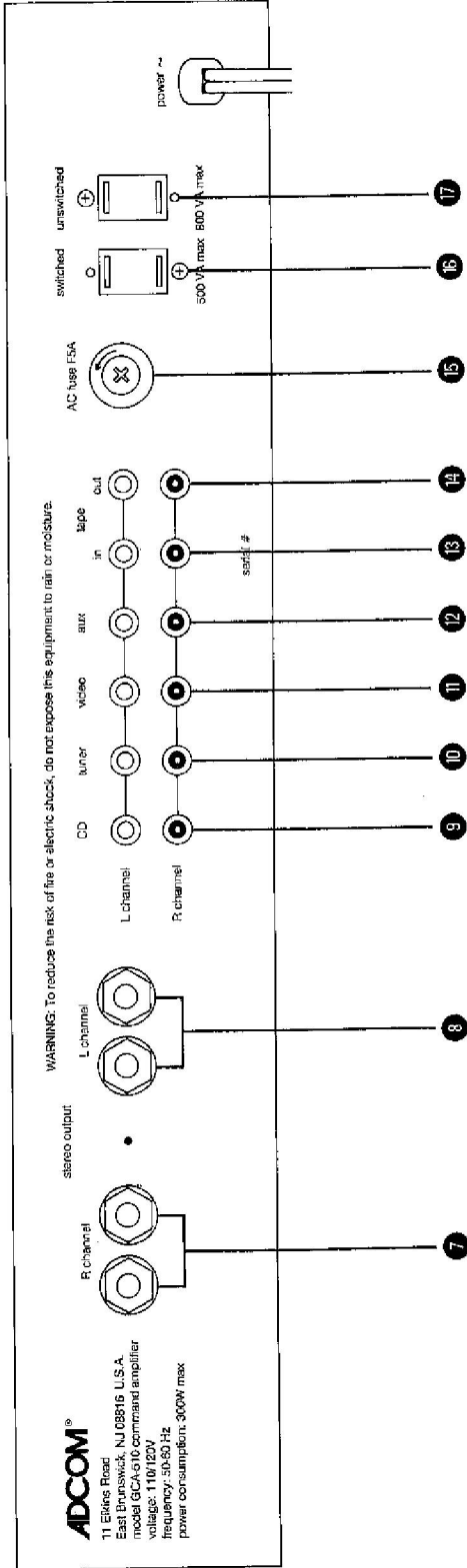

WARNING: To reduce the risk of fire or electric shock, do not expose this equipment to rain or moisture.

- 7 Stereo (speaker) output - right channel
- 8 Stereo (speaker) output - left channel
- 9 CD input
- 10 Tuner input
- 11 Video input
- 12 Aux input
- 13 Tape input
- 14 Tape output
- 15 AC (mains) fuse holder
- 16 Switched AC outlet (US models only)
- 17 Unswitched AC outlet (US models only)

## HOOK UP AND OPERATING INSTRUCTIONS

- 1) Unpack the GCA-510 carefully. Put the foam cocoon and other packing materials back in the carton and **SAVE IT.**  
As part of ADCOM's quality control procedures, your GCA-510 was carefully inspected for physical imperfections and electrical performance before it left our plant. In the event of physical damage, notify your ADCOM dealer immediately and request help in filing a written damage claim.

**THE RIGHT TO A CLAIM AGAINST A COMMON CARRIER CAN BE FORFEITED IF THE CARRIER IS NOT NOTIFIED PROMPTLY IN WRITING AND IF THE SHIPPING CARTON AND PACKING MATERIALS ARE NOT AVAILABLE FOR INSPECTION. SAVE ALL PACKING MATERIALS UNTIL THE CLAIM HAS BEEN SETTLED.**

The foam cocoon and carton were specifically designed to protect your GCA-510. Even though space is often at a premium in today's homes, we recommend that you save the packing materials in case you need to ship the unit anywhere in the future.

- 2) Select a stable, vibration-free location for the GCA-510 as close as possible to your other audio components. Make sure you have enough air space for proper ventilation. We recommend at least 3" of free air space above the GCA-510 and an inch to each side and to the rear of the unit.

The GCA-510 is heavier than you might expect due to the high capacity toroidal transformer and large heat sink assembly. A stable supporting surface is necessary. We won't go into the endless and mostly unproved theories about extraneous vibrations and their deleterious effects on audio components except to say that the more massive and firmly anchored the supporting surface is, the less likely you'll be to experience any problems.

Proper airflow is important. Don't block the ventilation slots on the bottom plate and top cover of the unit. The feet will insure enough air space below the GCA-510 for adequate circulation. **WE RECOMMEND THAT YOU DO NOT STACK OTHER UNITS ON TOP OF THE GCA-510.**

- 3) Turn off all the other components in your system. That means everything. And don't plug the GCA-510 into the AC outlet yet.

Turning off system components before initial installation and connection avoids the nasty buzzes, thumps, and other sounds of electronic distress that occasionally accompanies hooking up components.

- 4) Connect the speakers to the 5-way binding posts (**speaker outputs**) of the GCA-510 (7 & 8). The binding posts will accept a variety of connectors from bare wire to exotic audiophile "super banana" types. Make sure to observe proper polarity: Connect the GCA-510's "+" (red) terminal for the left speaker to the "+" terminal on that speaker. Do the same for the "-" terminals. Then repeat this for the right speaker.

Exercise care in connecting your speakers. Be particularly alert that individual strands of speaker wire do not short between the "+" and "-" terminals at either the amplifier or the speaker terminals.

A note on speaker cable: We recommend the use of at least 16 gauge (AWG) two conductor "zip" cord for all speaker connections under 25' in length. For longer amplifier-to-speaker runs, we suggest 14 gauge "zip" cord. If you so desire, specialty wire specifically designed for high quality amplifier-speaker interface may be considered. Consult your ADCOM dealer for recommendations.

- 5) Connect the outputs of up to five (5) line level sources (CD player, tuner, etc.) to the appropriate inputs on the rear panel of the GCA-510 (9 through 13). All inputs are electrically identical.

Remember to observe proper channel continuity — left channel output to left channel input and right to right. The RCA-type input jacks on ADCOM products adhere to the color convention of white for left channel and red for right. Most dual coaxial interconnect cables (or "patch" cords) also follow this color coding or mark the cables in other obvious ways to make channel continuity easy to establish.

A note on interconnects: We strongly recommend cables with low capacitance ratings. These will provide minimum interference for component-to-component signal transfer. If you desire, you may opt for specialty interconnects specifically designed for low loss signal transfer. Consult your ADCOM dealer for recommendations.

- 6) The "Tape Out" connections (14) should be connected to the inputs of your system's tape or disc recorder. As long as you do not attempt to run a patch cord from either channel's "Tape Out" to a digital recorder's digital input, you should experience no problem.

If you do attempt this feat, you will not be punished. Nothing will happen. Absolutely nothing. Eventually, you'll realize the mistake and correct it by connecting the GCA-510's "Tape Out" jacks to the *analog* inputs of the digital recording device. Then you'll be able to record.

The "Tape Out" jacks are buffered (or isolated) to preserve signal integrity under unusual load conditions. In other words, the GCA-510's sound quality will be unaffected by any conditions inadvertently imposed by the recording device (low impedances, electrical short circuits, etc.)

- 7) (This information applies only to certain versions of the GCA-510. Consult your dealer for details.)

The GCA-510 is equipped with two rear panel convenience AC outlets; one switched (16) and one unswitched (17). Power to

the switched outlet is controlled by the front panel Power switch while the unswitched outlet carries AC current whenever the GCA-510 is plugged into a live AC outlet. The power ratings for these outlets are as follows: 500 VA (equivalent to 500 watts) maximum for the switched outlet and 800 VA (or watts) maximum for the unswitched outlet.

The switched outlet can be used for any system component that should be turned on or off when the GCA-510 is powered. Tuners and CD players are the most likely candidates. The unswitched outlet is recommended for mechanical devices such as a cassette deck where premature AC power interruption can result in damage to the drive assembly or for other source components where a constant AC source is required to maintain internal settings.

- 8) After making sure that the "Level" control ⑥ is turned completely down (counter-clockwise), plug the GCA-510 into an AC outlet, preferably one that is NOT controlled by a wall switch or other device that may be turned off inadvertently. If you live in an area supplied with 115 Volt AC, we strongly recommend use of ADCOM's ACE-515 AC line enhancer and sequential switcher. See your ADCOM dealer for details.
- 9) Use the "Power" switch ① to turn the GCA-510 on. The "Power Indicator LED" ② will light.
- 10) Select a source for playback by rotating the "Listening" selector ④ to the appropriate input position. You may select the same source to record by rotating the "Recording" selector ⑤ to the same input.

You can simultaneously select a totally different source for recording by simply selecting a different source with the "Recording" switch.

The GCA-510 will not allow a potentially destructive feedback condition even if you inadvertently set both the "Listening" and "Recording" switches to the Tape position. In this case, the GCA-510 will automatically mute the recording output.

## CARE AND FEEDING OF THE GCA-510

ADCOM has taken great care to assure that your GCA-510 is as flawless in appearance as it is electrically. The front panel is a heavy-gauge, high grade anodized aluminum extrusion bead blasted for durability. The chassis, rear panel and top cover are painted and baked heavy gauge steel.

If the outer cover or front panel becomes dusty or fingerprinted, please clean with a soft, lintless cloth, **SLIGHTLY DAMPENED** with a very mild detergent solution.

**DO NOT SPRAY OR USE LIQUIDS OF ANY KIND ON YOUR UNIT!  
NEVER USE HARSH SCOURING POWDERS!**

## SERVICING

ADCOM's Technical Service Department will be happy to answer all questions pertaining to the installation and operation of your unit. In the unlikely event of difficulty, please contact us for prompt advice. If we can't help you resolve the problem immediately, we may refer you to an authorized repair agency, or authorize the return of your unit to our plant.

All written inquiries should be addressed to:

ADCOM Service Department  
11 Elkins Road  
East Brunswick, NJ.08816  
USA

Telephone inquiries are welcomed from Monday through Friday between 9 AM and 4 PM, Eastern Time: (908) 390-1130

We'll also be happy to answer FAX inquiries. Direct them to: (908) 390-9152 and include your FAX number for our response.

When inquiring about your unit, please include the serial number, the name of the dealer from whom you purchased the unit and the date of purchase.

If we ask you to return the unit to us for service, we will issue a specific Return Authorization number for your use. **UNDER NO CIRCUMSTANCES SHOULD THE UNIT BE SHIPPED TO US WITHOUT PROPER AUTHORIZATION OR PACKED IN ANYTHING OTHER THAN ITS ORIGINAL PACKING.**

If the original packing has been lost, discarded or damaged, we will be happy to supply a replacement at a nominal charge. Please mention your need when you call or write.

Always ship PREPAID via UPS (United Parcel Service) or other appropriate carrier. **FREIGHT COLLECT SHIPMENTS WILL BE REFUSED. DO NOT SHIP VIA PARCEL POST** as the packaging will not necessarily withstand handling by our Postal Service.

# GCA-510 SPECIFICATIONS

## Power Rating (To FTC Requirements)

50 watts continuous average power into 8 ohms at any frequency between 20Hz and 20kHz with both channels driven at less than 0.075% THD.

75 watts continuous average power into 4 ohms at any frequency between 20Hz and 20kHz with both channels driven at less than 0.075% THD.

## IM Distortion (SMPTE)

1 watt to 50 watts into 8 ohms .....  $\leq$  0.05%  
 1 watt to 75 watts into 4 ohms .....  $\leq$  0.05%

## IM Distortion (CCIF, Any Combination from 4kHz to 20kHz)

50 watts into 8 ohms .....  $\leq$  0.02%  
 75 watts into 4 ohms .....  $\leq$  0.02%

## THD + Noise at 50 watts into 8 Ohms (Typical)

20Hz ..... 0.012%  
 10kHz ..... 0.035%  
 20kHz ..... 0.05%

## THD + Noise at 75 watts into 4 Ohms (Typical)

20Hz ..... 0.025%  
 1kHz ..... 0.018%  
 10kHz ..... 0.04%  
 20kHz ..... 0.055%

## Frequency Response @ 1 Watt into 8 Ohms

10Hz to 20kHz ..... +0,-.5dB

Power Bandwidth (-3dB) ..... 3Hz to 100kHz

Dynamic Headroom into 4 Ohms ..... 2.3dB

## Signal to Noise Ratio, "A" Weighted

50 watts into 8 ohms .....  $\geq$  105dB

Gain (Volume control @ Maximum) ..... 31dB

## Damping Factor

20Hz to 20kHz .....  $\geq$  380

## Rise Time

5kHz, 65V peak to peak square wave, 20% to 80% ..... 1.5us

Semiconductor complement ..... 33 transistors, 2 zener diodes,  
 10 diodes, 1 IC, 1 diode bridge

## Power Consumption (Continuous, Both Channels Driven)

Quiescent ..... 50VA  
 Maximum ..... 600VA  
 50 watts into 8 ohms ..... 275VA  
 75 watts into 4 ohms ..... 420VA

## General

Power (available in 220V or 240V on special order) ..... 120VAC/50-60Hz

Chassis Dimensions ..... 3"(76mm) x 17"(432mm) x 11<sup>1</sup>/<sub>4</sub>"(286mm)

Maximum Dimensions ..... 3<sup>1</sup>/<sub>2</sub>"(89mm) x 17"(432mm) x 13"(330mm)

Weight ..... 15 lbs.(6.8kg)

Weight, Packed ..... 17.5 lbs.(7.9kg)